

LINOVISION

IOT-S500WS6P

Quick Start Guide

Updated on July26,2024

Safety Precautions

Linovision will not shoulder responsibility for any loss or damage resulting from not following the instructions of this operating guide.

The device must not be disassembled or remodeled in any way.

- In order to protect the security of the device, please change device password when first configuration. The default password is 123456.
- The device is not intended to be used as a reference sensor, and Linovision will not should responsibility for any damage which may result from inaccurate readings.
- Do not place the device close to objects with naked flames.
- Do not place the device where the temperature is below/above the operating range.
- Make sure electronic components do not drop out of the enclosure while opening.
- When installing the battery, please install it accurately, and do not install the reverse or wrong model.
- Make sure both batteries are newest when install, or battery life will be reduced.
- The device must never be subjected to shocks or impacts.

Declaration of Conformity

WS series is in conformity with the essential requirements and other relevant provisions of the CE, FCC, and RoHS.



Copyright © 2007-2022Linovision. All rights reserved.

All information in this guide is protected by copyright law. Whereby, no organization or individual shall copy or reproduce the whole or part of this user guide by any means without written authorization from Hangzhou Linovision Technologies Co.,Ltd.

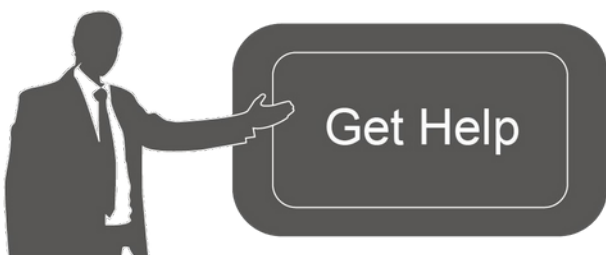

For assistance, please contact
Linovision technical support: Email:
sales@linovision.com
Tel: +1(469)-444-2999
URL:support.linovision.com
Address: 701 E Plano Parkway, Ste 100
Plano, Texas, 75074
U.S.A

Contents

| | |
|---|----|
| 1. Product Introduction | 4 |
| 1.1 Overview | 4 |
| 1.2 Features | 4 |
| 2. Hardware Introduction | 4 |
| 2.1 Packing List | 4 |
| 2.3 LED and Power Button | 6 |
| 3. Operation Guide | 6 |
| 3.1 NFC Configuration | 6 |
| 3.2 LoRaWAN Settings | 8 |
| 3.3 Basic Settings | 11 |
| 3.4 Advanced Settings | 11 |
| 3.4.1 Threshold Settings | 11 |
| 3.4.2 Data Storage | 12 |
| 3.4.3 Data Retransmission | 13 |
| 3.5 Maintenance | 14 |
| 3.5.1 Upgrade | 14 |
| 3.5.2 Backup | 15 |
| 3.5.3 Reset to Factory Default | 17 |
| 4. Installation and Maintenance | 18 |
| 4.1 Installation Locations | 18 |
| 4.2 Solar Panel and WS Hub Installation | 18 |
| 4.3 IOT-S500WS6P Installation | 20 |
| 4.4 Maintenance | 21 |
| 5. Device Payload | 21 |
| 5.1 Basic Information | 21 |
| 5.2 Sensor Data | 22 |
| 5.3 Downlink Commands | 23 |
| 5.4 Historical Data Enquiry | 26 |

1. Product Introduction

1.1 Overview

IoT Weather Station (IOT-S500WS6P) is an all-in-one LoRaWAN® weather monitoring system for various atmospheric conditions, such as temperature, humidity, wind speed, wind direction, barometric pressure and rainfall. Consisting of 3 main parts, sensors, Hub and solar panel, IoT Weather Station is designed to withstand the most challenging weather conditions and is easy to install in different scenarios to be widely used in meteorology, smart agriculture, smart building, etc.

Sensor data is transmitted using LoRaWAN® technology. Compliant with Linovision LoRaWAN® gateway and Linovision IoT Cloud solution, users can manage all sensor data and trigger other sensors or appliances easily via webpage or mobile App remotely.

1.2 Features

- Integrated with multiple sensors like humidity, temperature, barometric pressure, wind speed, wind direction, rainfall, etc.
- Waterproof, UV-proof and salt spray resistant enclosure for outdoor harsh environment applications
- High power solar powered with chargeable batteries backup
- Store locally more than 19,000 historical records and support retransmission to ensure no data miss
- Easy to carry and install
- Ultra-wide-distance wireless transmission up to the line of sight of 15 km in rural areas
- Equipped with NFC for easy and quick configuration
- Compliant with standard LoRaWAN gateways and network servers
- Quick and easy management with Linovision IoT Cloud

2. Hardware Introduction

2.1 Packing List



1 × WS Sensor



1 × WS Hub



1 × Solar Panel
(With Bracket)



1 × Solar Panel
Mounting Bracket



1 × Sensor Cable

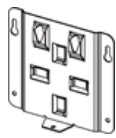

1 × WS Hub
Mounting Bracket



5 × Fixing Screws



4 × Solar Panel
Screws Kits



2 × Hose Clamps



1 × Quick Start
Guide



1 × Mounting
Bracket



1 × Bent Pipe



3 × Hex Socket Cap
Mounting Screws



2 × Hose Clamps



If any of the above items is missing or damaged, please contact your sales representative.

2.2 Dimensions(mm)

WS Hub

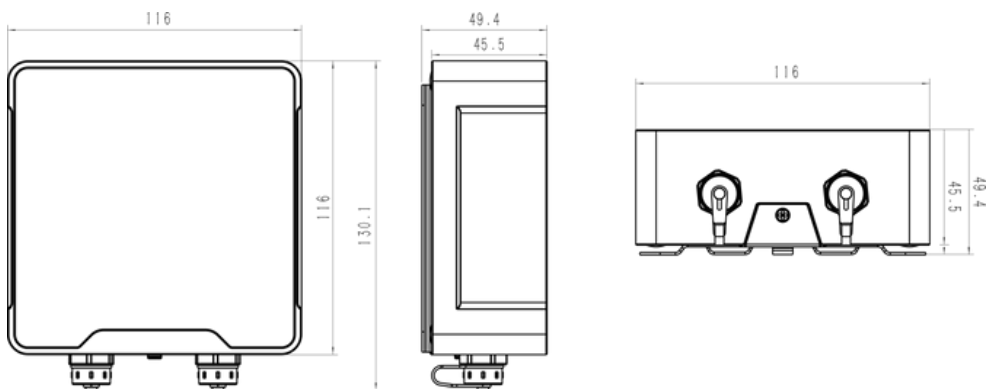

IOT-S500WS6P

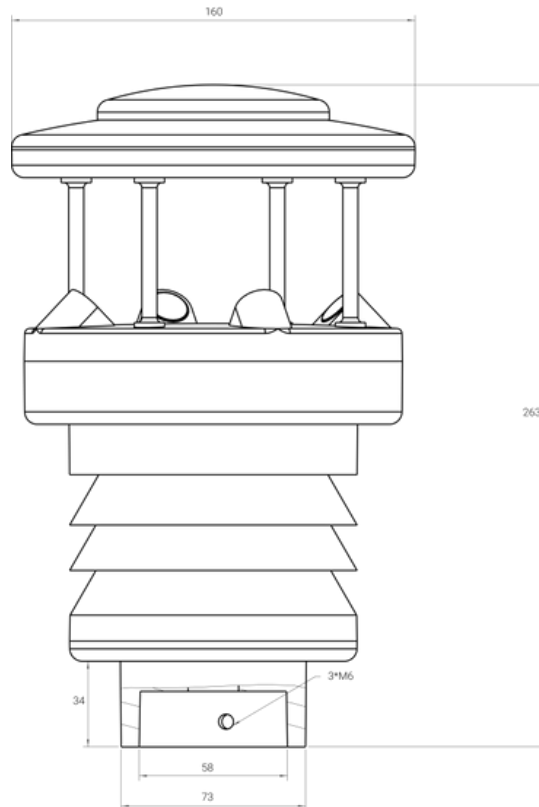

2.3 LED and Power Button

The LED indicator and power button are inside the WS Hub device. Switch on/off and reset can also be configured via NFC.

| Function | Action | LED Indication |
|---------------------|--|---------------------------|
| Turn On | Press and hold the button for more than 3 seconds. | Off → On |
| Turn Off | Press and hold the button for more than 3 seconds. | On → Off |
| Reset | Press and hold the button for more than 10 seconds. | Blink 3 times. |
| Check On/Off Status | Quickly press the power button for within 3 seconds. | Light On: Device is on. |
| | | Light Off: Device is off. |

3. Operation Guide

3.1 NFC Configuration

WS Hub can be configured via NFC. Before the configuration, please connect WS Sensor to the right interface of WS Hub via sensor cable to read and test. 1. Download and install "Linovision ToolBox" App from Google Play or Apple Store.

2. Enable NFC on the smartphone and open “Linovision ToolBox” App. 3. Attach the smartphone with NFC area to the device to read basic information.

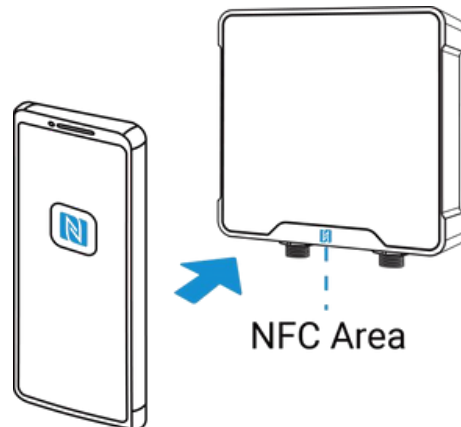

4. Basic information and settings of WS Hub will be shown on Toolbox if it’s recognized successfully. You can read and configure the device by tapping the buttons on the App. In order to protect the security of devices, password validation is required when configuring via unused phone . Default password is 123456.

| Status | Setting | Maintenance |
|------------------|------------------|-------------------------------------|
| SN | 6454C32424650043 | |
| Model | WTS506-915M | |
| Device EUI | 24E124454C324246 | |
| Firmware Version | V1.1-a3 | |
| Hardware Version | V2.0 | |
| Device Status | ON | <input checked="" type="checkbox"/> |

Note: 1) Ensure the location of smartphone NFC area and it’s recommended to take off phone case. 2) If the smartphone fails to read/write configurations via NFC, keep the phone away and back to try again. 3) WS Hub can also be configured by dedicated NFC reader provided by Linovision IoT. 4) You can configure it via Type-C USB port inside the device by these steps: release the back panel of WS Hub and connect the device to computer via Type-C port, run Toolbox PC software, select serial port as USB port and type as “General”, then type password to login Toolbox and configure the device. (Default password: 123456)

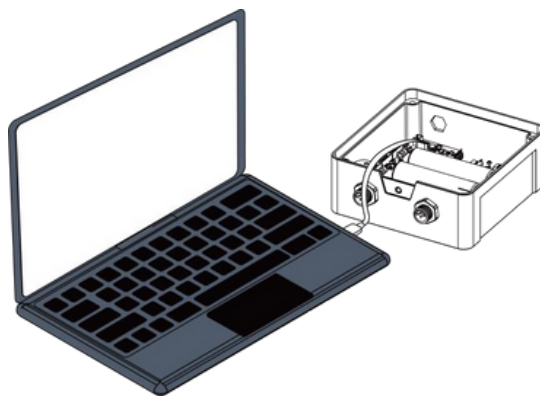

3.2 LoRaWAN Settings

LoRaWAN settings is used for configuring the transmission parameters in LoRaWAN® network.

Basic LoRaWAN Settings:

Configure join type, App EUI, App Key and other basic information. You can also keep all settings by default.

| | |
|--------------------------------|---|
| Device EUI | <input type="text" value="24E1244"/> |
| App EUI | <input type="text" value="24E124C0002A0001"/> |
| Application Port | <input type="text" value="85"/> |
| Working Mode: | <input type="text" value="Class A"/> |
| Join Type | <input type="text" value="OTAA"/> |
| Application Key | <input type="text" value="*****"/> |
| RX2 Date Rate | <input type="text" value="DR8 (SF12, 500k)"/> |
| RX2 Frequency | <input type="text" value="923300000"/> |
| Spread Factor | <input type="text" value="SF7-DR3"/> |
| Confirmed Mode | <input type="checkbox"/> |
| Rejoin Mode | <input checked="" type="checkbox"/> |
| Set the number of packets sent | <input type="text" value="32"/> packets |
| ADR Mode | <input checked="" type="checkbox"/> |
| TXPower | <input type="text" value="TXPower0-22 dBm"/> |

| Parameters | Description |
|------------|---|
| Device EUI | Unique ID of the device which can also be found on the label. |

| | |
|--------------------------------|---|
| App EUI | Default App EUI is 24E124C0002A0001. |
| Application Port | The port used for sending and receiving data, default port is 85. |
| Join Type | OTAA and ABP mode are available. |
| Application Key | Appkey for OTAA mode, default is 5572404C696E6B4C6F52613230313823. |
| Device Address | DevAddr for ABP mode, default is the 5th to 12th digits of SN. |
| Network Session Key | Nwkskey for ABP mode, default is 5572404C696E6B4C6F52613230313823. |
| Application Session Key | Appskey for ABP mode, default is 5572404C696E6B4C6F52613230313823. |
| LoRaWAN Version | V1.0.2, V1.0.3 are available. |
| RX2 Data Rate | RX2 data rate to receive downlinks. |
| RX2 Frequency | RX2 frequency to receive downlinks. Unit: Hz |
| Spread Factor | If ADR is disabled, the device will send data via this spread factor. |
| Confirmed Mode | If the device does not receive ACK packet from network server, it will resend data once. |
| Rejoin Mode | Reporting interval \leq 35 mins: the device will send a specific number of LinkCheckReq MAC packets to the network server every reporting interval or every double reporting interval to validate connectivity; If there is no response, the device will re-join the network. Reporting interval $>$ 35 mins: the device will send a specific number of LinkCheckReq MAC packets to the network server every reporting interval to validate connectivity; If there is no response, the device will re-join the network. |
| Set the number of packets sent | When the rejoin mode is enabled, set the number of LinkCheckReq packets to send . Note: the actual sending number is Set the number of packet sent + 1. Allownetworkservertoadjustdatarateofthedevice. |
| ADRMMode | Transmitpowerofdevice. |
| TxPower | |

Note:

- 1) Please contact sales for device EUI list if there are many units.
- 2) Please contact sales if you need random App keys before purchase.
- 3) Select OTAA mode if you use Linovision IoT Cloud to manage devices.
- 4) Only OTAA mode supports rejoin mode.

LoRaWAN Frequency Settings:

Select supported frequency and select channels to send uplinks. Make sure the channels match the LoRaWAN® gateway.

Support Frequency : **EU868**

| <input type="checkbox"/> | Index | Frequency/MHz | Max Datarate | Min Datarate |
|-------------------------------------|-------|---------------|--------------|--------------|
| <input checked="" type="checkbox"/> | 0 | 868.1 | 5-SF7BW125 | 0-SF12BW125 |
| <input checked="" type="checkbox"/> | 1 | 868.3 | 5-SF7BW125 | 0-SF12BW125 |
| <input checked="" type="checkbox"/> | 2 | 868.5 | 5-SF7BW125 | 0-SF12BW125 |
| <input type="checkbox"/> | 3 | 0 | 5-SF7BW125 | 0-SF12BW125 |
| <input type="checkbox"/> | 4 | 0 | 5-SF7BW125 | 0-SF12BW125 |
| <input type="checkbox"/> | 5 | 0 | 5-SF7BW125 | 0-SF12BW125 |
| <input type="checkbox"/> | 6 | 0 | 5-SF7BW125 | 0-SF12BW125 |

If the frequency is one of CN470/AU915/US915, you can enter the index of the channel that you want to enable in the input box, making them separated by commas.

Examples:

1, 40: Enabling Channel 1 and Channel 40

1-40: Enabling Channel 1 to Channel 40

1-40, 60: Enabling Channel 1 to Channel 40 and Channel 60

All: Enabling all channels

Null: Indicates that all channels are disabled

Support Frequency : **AU915**

Enabled Channel Index:

| Channel Index | Frequency/MHz | Channel Spacing/MHz | BW/kHz |
|---------------|---------------|---------------------|--------|
| 0 - 15 | 915.2 - 918.2 | 0.2 | 125 |
| 16 - 31 | 918.4 - 921.4 | 0.2 | 125 |
| 32 - 47 | 921.6 - 924.6 | 0.2 | 125 |
| 48 - 63 | 924.8 - 927.8 | 0.2 | 125 |
| 64 - 71 | 915.9 - 927.1 | 1.6 | 500 |

3.3 Basic Settings

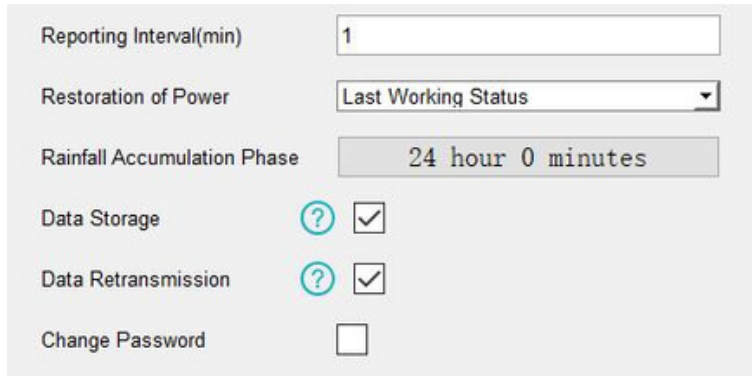

| Parameters | Description |
|--|--|
| Reporting Interval | Reporting interval of transmitting weather data and battery level to network server. Default: 10 mins, Range: 1-1080 mins. |
| Restoration of Power | If the device loses power and returns to power supply, the device will be on or off according to this parameter. |
| Rainfall Accumulation Phase (IOT-S500WS6P Only) | <p>After the rainfall accumulates up to this time range or up to 1000 mm, it will clear and re-count the accumulated rainfall value. There are two parameters to set the time range, range: 0~48 h</p> |
| Data Storage | Disable or enable reporting data storage locally. |
| Data Retransmission | Disable or enable data retransmission. |
| Change Password | Change the password for ToolBox App to write the device and ToolBox software to configure this device. |

3.4 Advanced Settings

3.4.1 Threshold Settings

If the threshold is triggered, the device will upload the alarm packet once and collect the data at

the specified interval.

| | |
|--------------------------|--------------------------------------|
| Temperature | <input checked="" type="checkbox"/> |
| Over | <input type="text" value="29.9"/> °C |
| Below | <input type="text" value="15"/> °C |
| Data Collecting Interval | <input type="text" value="10"/> min |
| Wind Speed | <input checked="" type="checkbox"/> |
| Over | <input type="text" value="0"/> m/s |
| Data Collecting Interval | <input type="text" value="10"/> min |
| Accumulated Rainfall | <input type="checkbox"/> |
| Barometric Pressure | <input type="checkbox"/> |

3.4.2 Data Storage

WS series supports storing more than 19,000 data records locally and exports data via ToolBox App or ToolBox software. The device will record the data according to reporting interval even not joining to network. 1. Sync the time via ToolBox or downlink commands.

| | |
|-------------------------|---|
| Channel Mask: | 0003 |
| Uplink Frame-counter: | 86 |
| Downlink Frame-counter: | 0 |
| Device Time: | 2022-10-10 07:26:15 <input type="button" value="Sync"/> |

| Status | Setting | Maintenance |
|------------------|------------------|-------------------------------------|
| SN | 6454C32424650043 | |
| Model | WTS506-915M | |
| Device EUI | 24E124454C324246 | |
| Firmware Version | V1.1-a4 | |
| Hardware Version | V2.0 | |
| Device Status | ON | <input checked="" type="checkbox"/> |
| Join Status | De-activated | |
| RSSI/SNR | 0/0 | |
| Device Time | 2022-10-10 14:54 | <input type="button" value="Sync"/> |

2. Enable data storage feature.

3. Go to Maintenance > Basic of ToolBox software or Device > Maintenance of ToolBox App, click Export, then select the data time period and click Save to export data.

Note: Toolbox App can only export last 14 days' data. If you need to export more data, please use Toolbox software.

4. Click Clear of ToolBox software or Data Cleaning of ToolBox App to clear all stored data if necessary.

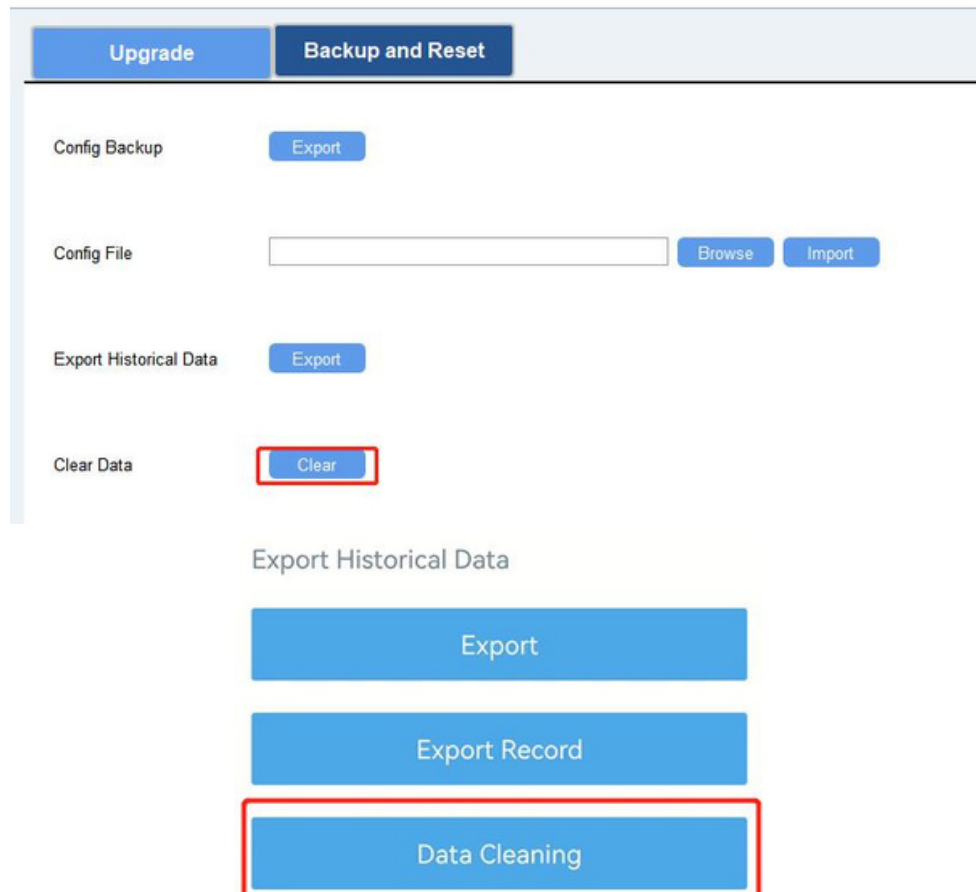

3.4.3 Data Retransmission

WS series supports data retransmission to ensure network sever can get all data even if network is down for some times. There are two ways to get the lost data:

- Network server sends downlink commands to enquire the historical data for specifying time range, refer section [Historical Data Enquiry](#);
- When network is down if no response from LinkCheckReq MAC packets for a period of time, the device will record the network disconnected time and re-transmit the lost data after device re-connects the network.

Here are the steps for data retransmission:

1. Enable data storage feature and data retransmission feature.

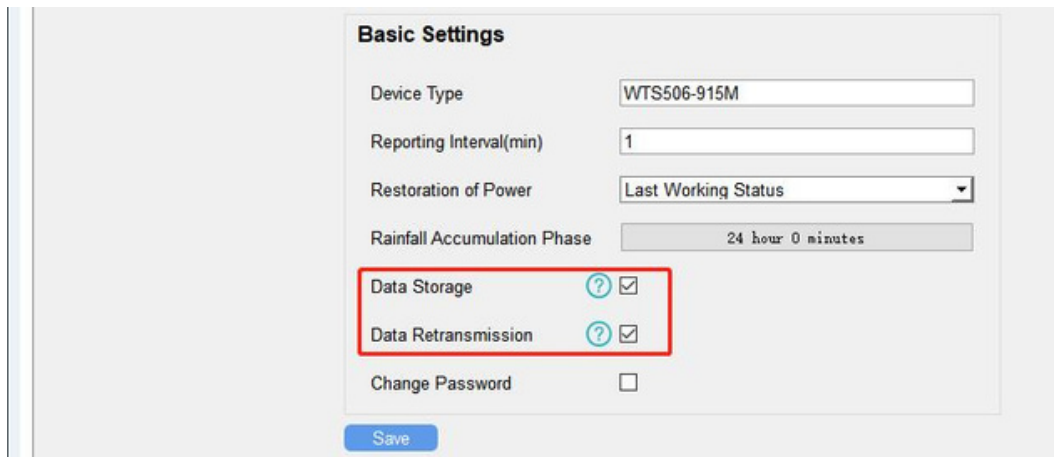

2. Enable rejoin mode feature and set the number of packets sent. Take below as example, the device will send LinkCheckReq MAC packets to the network server regularly to check if the network is disconnected; if there is no response for 4+1 times, the join status will change to de-active and the device will record a data lost time point (the time to join the network).

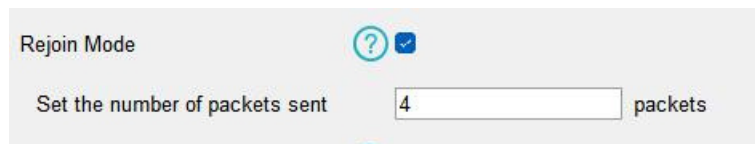

3. After the network connected back, the device will send the lost data from the point in time when the data was lost according to the reporting interval.

Note:

- 1) If the device is reboot or re-powered when data retransmission is not completed, the device will re-send all retransmission data again after device is reconnected to the network.
- 2) If the network is disconnected again during data retransmission, it will only send the latest disconnection data.
- 3) The retransmission data format is started with "20ce", please refer to section [Historical Data Enquiry](#).
- 4) Data retransmission will increase the uplinks and shorten the battery life.

3.5 Maintenance

3.5.1 Upgrade

ToolBox Software:

1. Download firmware from Linovision official website to your PC.
2. Click Browse to import the firmware and upgrade the firmware.

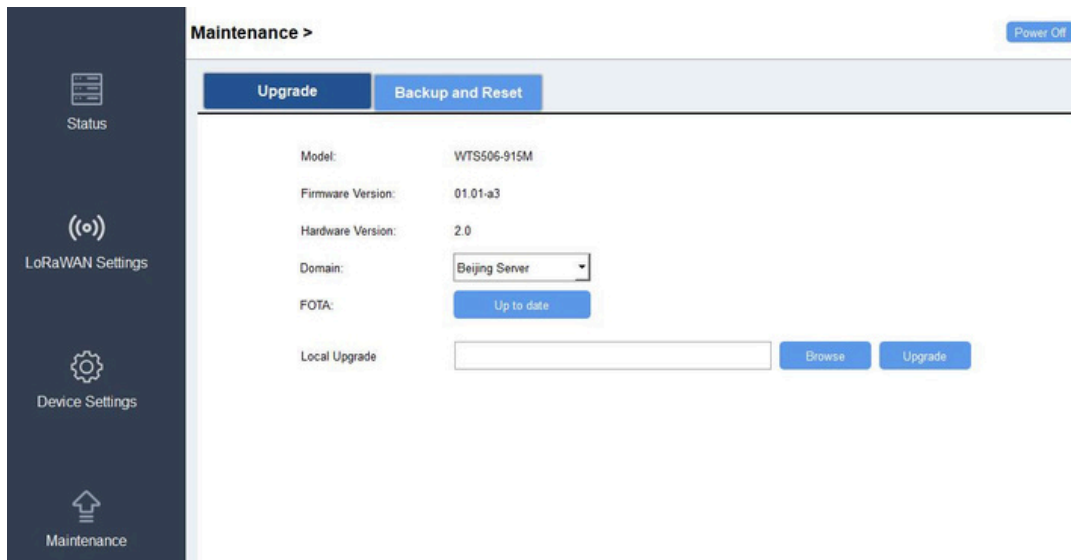

ToolBox App:

1. Download firmware from Linovision official website to your smartphone.
2. Click Browse to import firmware and upgrade the device. **Note: 1) It is not supported to do any operation on ToolBox during upgrading. 2) Only Android version ToolBox App supports upgrade feature.**

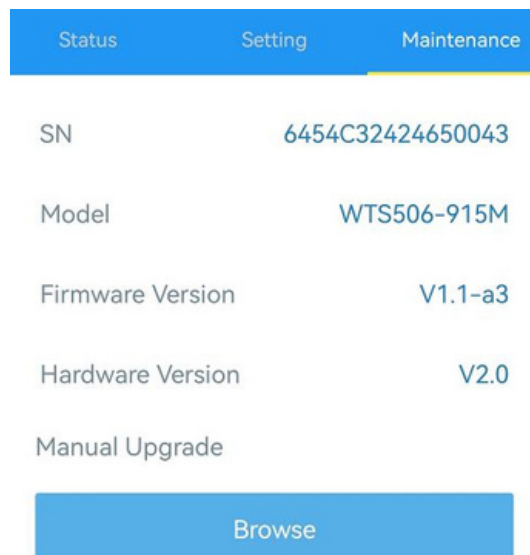

3.5.2 Backup

WS Hub supports configure backup for easy and quick device configuration in bulk. Backup is allowed only for devices with the same model and LoRaWAN® frequency band. Please select one of following methods to backup device:

ToolBox Software:

1. Go to Maintenance > Backup and Reset, click Export to save current configuration as json format backup file.
2. Click Browse to select backup file, then click Import to import the configurations.

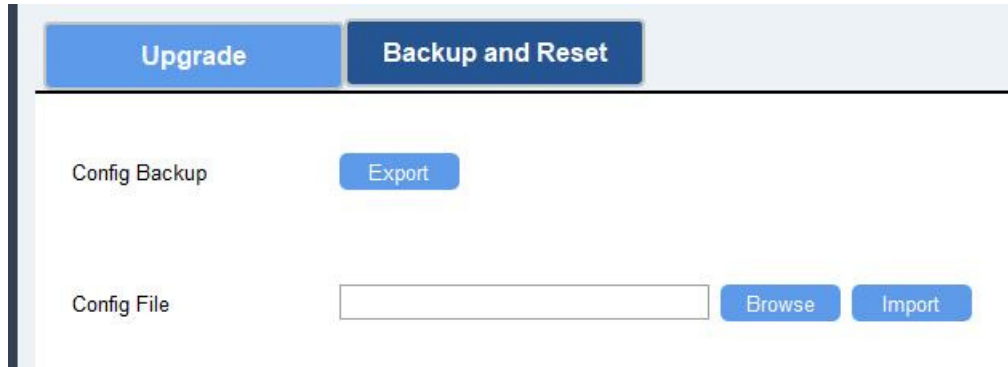

ToolBox App:

1. Go to Template page on the App and save current settings as a template. You can also edit the template file.
2. Select one template file which saved in the smartphone and click Write, then attach to another device to write configuration.

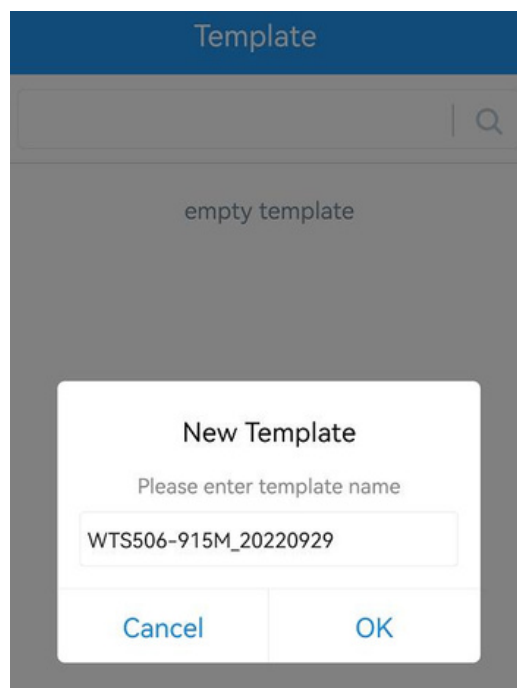

Note: Slide the template item left to edit or delete the template. Click the template to edit the configurations.

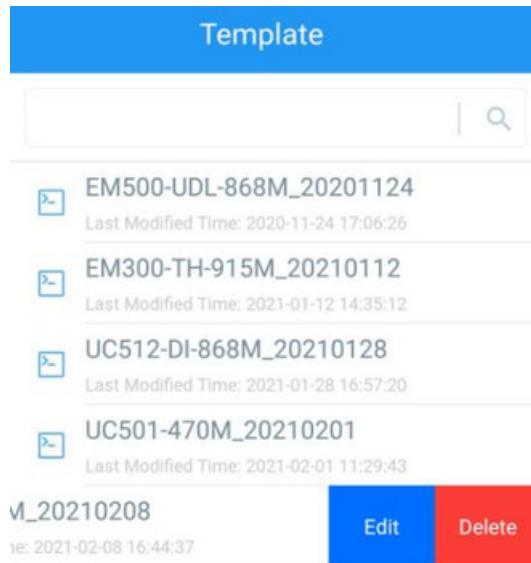

3.5.3 Reset to Factory Default

Please select one of following methods to reset device: [Via Hardware](#): Hold on power button (internal) of WS Hub for more than 10s. [Via ToolBox Software](#): Go to Maintenance > Backup and Reset to click Reset.

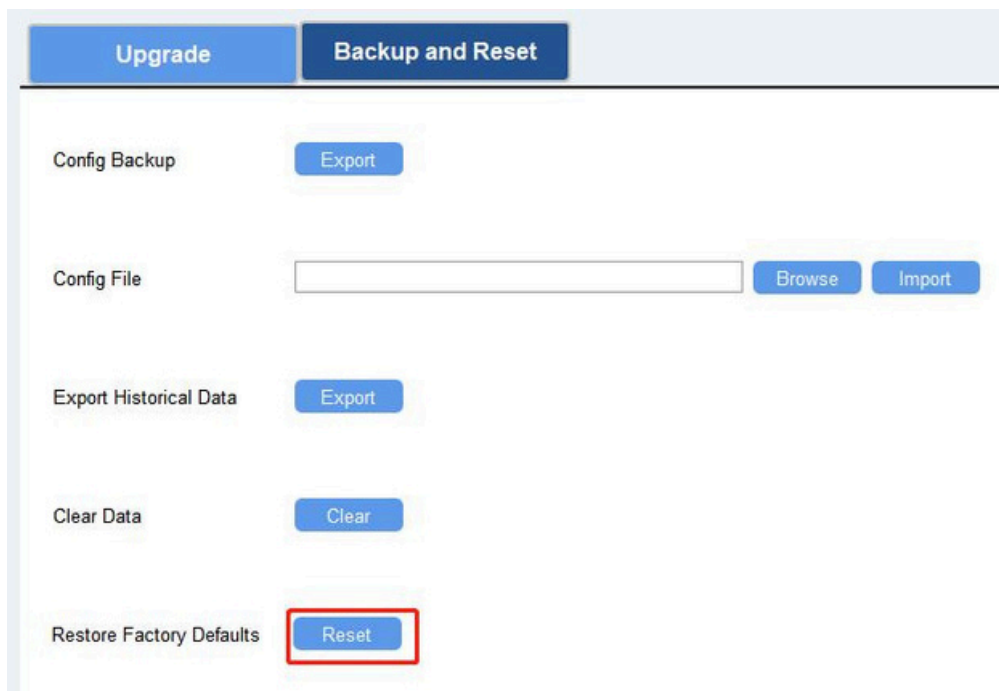

[Via ToolBox App](#): Go to Device > Maintenance to click Reset, then attach smart phone with NFC area to WS Hub to complete reset.

| Status | Setting | Maintenance |
|-------------------------|------------------|-------------|
| SN | 6454C32424650043 | |
| Model | WTS506-915M | |
| Firmware Version | V1.1-a3 | |
| Hardware Version | V2.0 | |
| Manual Upgrade | | |
| Browse | | |
| Restore Factory Default | | |
| Reset | | |

4. Installation and Maintenance

4.1 Installation Locations

- Within the communication range of LoRaWAN® gateway.
- No high buildings or barriers (trees, telegraph poles) around; the distance between the IoT weather station and the nearest obstacle is preferably 10 times the height of the obstacle.
- Keep away from radars, transmitters and any other instruments which can generate electrical interference; keep a distance of more than 2 meters between sensor and radar.
- Keep away from heat sources like chimney, vents, etc.
- No fence plants (higher than 1m) around weather station within 10m.

4.2 Solar Panel and WS Hub Installation

1. Fix the hub mounting bracket to the solar panel bracket with 4 fixing screws, the put the WS Hub to the bracket fix the bottom of hub to the bracket with a fixing screw.

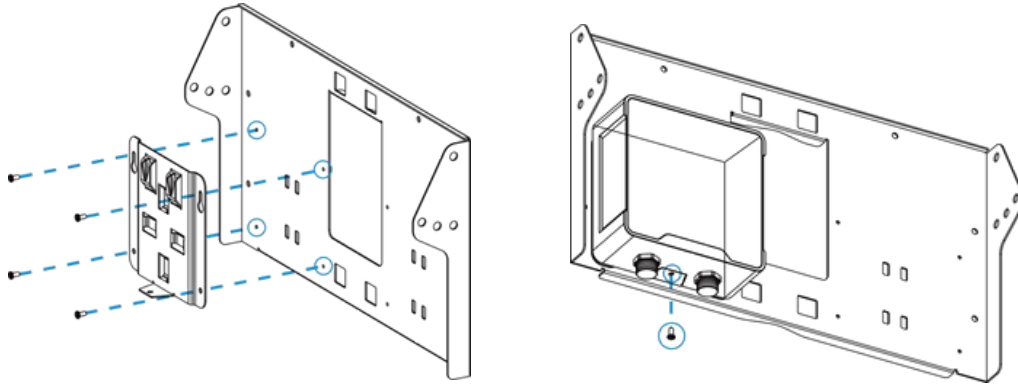

2. Adjust the angle of solar panel brackets (20°,40° or 60°is optional) according to the installation environment, then fix the two sides of bracket with screw kits.

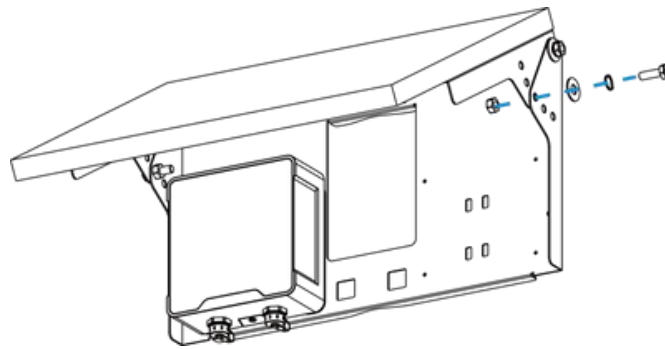

3. Straighten the hose clamps and slide them through the rectangular rings in the solar panel's bracket, wrap the hose clamps around the pole. After that use a screwdriver to tighten the locking mechanism by turning it clockwise.

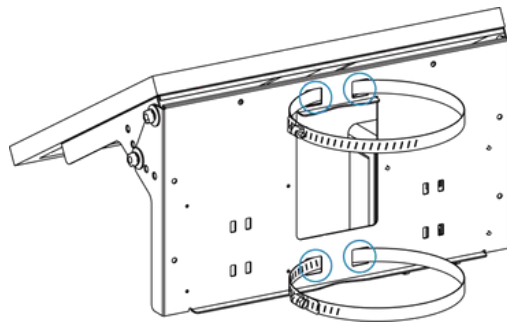

4. Connect the cable of solar panel to left interface of WS Hub.

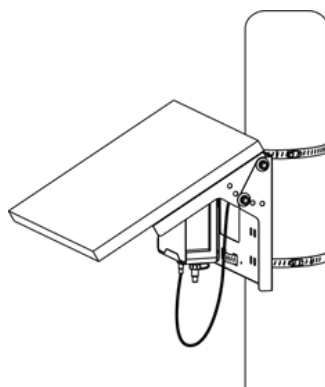

4.3 IOT-S500WS6P Installation

1. Connect the bent pipe to the mounting bracket, tighten the 2 hex socket cap screws with screwdriver and tighten the insurance screw by hand to ensure the two parts are fixed well.

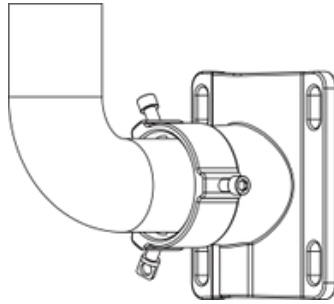

2. Connect one side of sensor cable to WS Sensor and tighten the cable, pass the cable through the bent pipe and bracket, then connect the pipe to the bottom of sensor and fix both parts with 3 hex socket cap mounting screws.

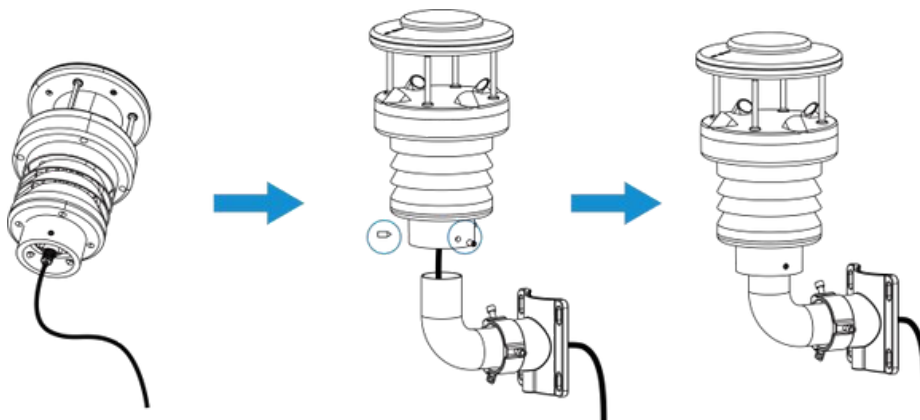

3. Straighten the hose clamps and slide them through the rings in the bracket, wrap the hose clamps around the pole. After that use a screwdriver to tighten the locking mechanism by turning it clockwise. When installing, ensure the arrow on the sensor facing north according to a compass.

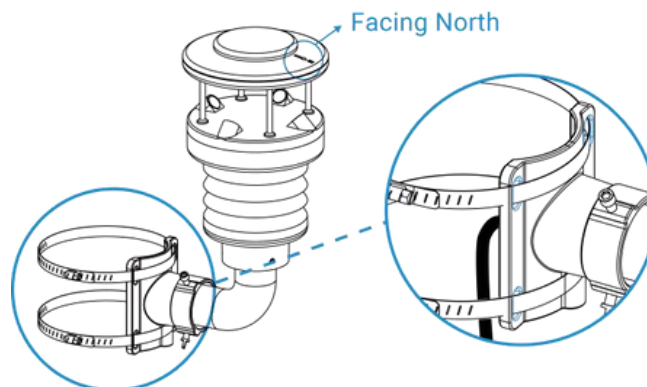

4. Connect the other side of sensor cable to the right interface of WS Hub.

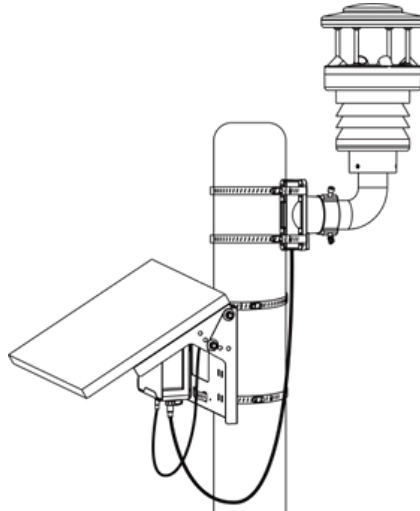

4.4 Maintenance

- To clean the device, wipe with a soft moistened cloth with soft detergents. When there is
- accumulated snow or ice on the surface of WS sensor, wait for it to dissolve naturally and do not remove with tools forcibly.
- Do not destroy the surface of devices and solar panel.

5. Device Payload

All data are based on following format (HEX), the Data field should follow little-endian:

| | | | | | | | |
|----------|-------|--------|----------|-------|--------|----------|-----|
| Channel1 | Type1 | Data1 | Channel2 | Type2 | Data2 | Channel3 | ... |
| 1Byte | 1Byte | NBytes | 1Byte | 1Byte | MBytes | 1Byte | ... |

5.1 Basic Information

WS series sensors report basic information of sensor whenever joining the network.

| Channel | Type | Description |
|---------|---------------------|-------------------------------|
| ff | 0b(PowerOn) | Deviceison |
| | 01(ProtocolVersion) | 01=>V1 |
| | 09(HardwareVersion) | 0140=>V1.4 |
| | 0a(SoftwareVersion) | 0114=>V1.14 |
| | 0f(DeviceType) | 00:ClassA,01:ClassB,02:ClassC |
| | 16(DeviceSN) | 16digits |

Example:

| ff0bff ff0101 ff166454c32424650043 ff090200 ff0a0101 ff0f00 | | | | | |
|---|------|-------|---------|------|-------|
| Channel | Type | Value | Channel | Type | Value |

| | | | | | |
|---------|-----------------------|------------------|---------|-----------------------|--------------|
| ff | 0b(Power on) | ff | ff | 01 (Protocol Version) | 01=V1 |
| Channel | Type | Value | Channel | Type | Value |
| ff | 16(Device SN) | 6454c32424650043 | ff | 09 (Hardware version) | 0200 (V2.0) |
| Channel | Type | Value | Channel | Type | Value |
| ff | 0a (Software version) | 0101 (V1.1) | ff | 0f (Device Type) | 00 (Class A) |

5.2 Sensor Data

| Item | Channel | Type | Description |
|---------------------------|---------|------|--|
| Battery Level | 01 | 75 | UINT8, Unit: % |
| Temperature | 03 | 67 | INT16/10, Unit: °C |
| Humidity | 04 | 68 | UINT8/2, Unit: %RH |
| Wind Direction | 05 | 84 | UINT16/10, Unit: ° |
| Barometric Pressure | 06 | 73 | UINT16/10, Unit: hPa |
| Wind Speed | 07 | 92 | UINT16/10, Unit: m/s |
| Rainfall | 08 | ec | 5 Bytes Byte 1-4: Accumulated rainfall, UINT32/100, Unit: mm Byte 5: Frame counter, calculate the uplink amounts of every phase, range: 0~255 Note: 1) When the rainfall is cleared and start a new accumulation phase, the counter will be also cleared to 0; 2) When frame counter reaches 255 and not enter a new phase, it will always report 255. |
| Temperature Alarm | 83 | 67 | Temperature (2 Bytes) + Alarm Status(1 Byte) Alarm Status: 01=Threshold Alarm |
| Barometric Pressure Alarm | 86 | 73 | Pressure (2 Bytes) + Alarm Status(1 Byte) Alarm Status: 01=Threshold Alarm |
| Wind Speed Alarm | 87 | 92 | Wind Speed (2 Bytes) + Alarm Status(1 Byte) Alarm Status: 01=Threshold Alarm |
| Rainfall Alarm | 88 | ec | Rainfall (4 Bytes) + Frame Counter (1 Byte) + Alarm Status(1 Byte) |

| | | | |
|--|--|--|---------------------------------|
| | | | Alarm Status:01=Threshold Alarm |
|--|--|--|---------------------------------|

Example:

1. Periodic packet

| 017564 03671001 046871 05844605 0673aa27 07929201 08ecc413000025 | | | | | |
|--|-----------------------------|---|---------|------------------------|-----------------------------------|
| Channel | Type | Value | Channel | Type | Value |
| 01 | 75 (Battery) | 64=>100% | 03 | 67 (Temperature) | 1001=>0110= 272/10=27.2°C |
| Channel | Type | Value | Channel | Type | Value |
| 04 | 68 (Humidity) | 71=>113 Hum=113/2=56.5% | 05 | 84 (Wind Direction) | 4605=>0546= 1350/10=135° |
| Channel | Type | Value | Channel | Type | Value |
| 06 | 73 (Barometric Pressure) | aa27=>27 aa=10154/10=10 15.4hPa | 07 | 92(Wind Speed) | 9201=>0192= 402/10=40.2 m/s |
| Channel | Type | Value | | | |
| 08 | ec(Rainfall) | c4130000=>000 013 c4 =5060/100=50.6 mm Counter=25=>37 | | | |

2. Threshold alarm: report when reaching the threshold.

| 83 67 0001 01 | | |
|---------------|---------------------|--|
| Channel | Type | Value |
| 83 | 67 (Temperature) | 0001=>0100=255*0.1=25.5°C 01=ThresholdAlarm |

5.3 Downlink Commands

WS series support downlink commands to configure the device. The application port is 85 by default.

| Item | Channel | Type | Description |
|-------------------|---------|------|---|
| ReportingInterval | ff | 03 | 2Bytes,unit:s |
| Reboot | | 10 | ff(Reserved) |
| DeviceTime | | 11 | 4Bytes,unixtimestamp |
| UTCTimeZone | | 17 | INT16/10 |
| ClearData | | 27 | 01: Clear Historical Data 00: Clear Accumulated Rainfall |

| | | | |
|-----------------------------|--|----|---|
| Restoration of Power | | 67 | 00: Off 01: On 02: Return to Previous Working State |
| Rainfall Accumulation Phase | | 6e | 2 Bytes, unit: min |
| Data Storage | | 68 | 01: Enable, 00: Disable |
| Data Retransmission | | 69 | 01: Enable, 00: Disable |
| Retransmission Interval | | 6a | 3 Bytes Byte 1: 00 Bytes 2-3: interval time, unit: s range: 30~1200s (600s by default) |
| Threshold Alarm-Temperature | | 06 | 9 Bytes, Temperature: CTRL(1B)+Min(2B)+Max(2B)+ 00000000(4B) CTRL: Bit0~Bit2: 001-below (minimum threshold) 010-over (maximum threshold) 011-within 100 -below or above Bit3~Bit5: 001 Bit6: 1=enable, 0=disable Bit7: 1 |
| Threshold Alarm | | 06 | 9 Bytes, Wind Speed/Pressure: CTRL(1B)+0000+Max(2B)+ 00000000(4B) Rainfall: CTRL(1B)+0000+Max_Low(2B)+0000+Max_ High (2B) CTRL: Bit0~Bit2: 010-over (maximum threshold) Bit3~Bit5: |

| | | | |
|---------------------|--|----|--|
| | | | 010-wind speed 011-rainfall 100-pressure Bit6: 1=enable, 0=disable Bit7: 1 |
| Collecting Interval | | bb | 3 Bytes, Byte 1: 01-temperature, 02-wind speed, 03-rainfall, 04-pressure Byte 2-3: collecting interval, unit: s |

Example:

1. Set reporting interval as 20 minutes.

| ff03b004 | | |
|----------|--------------------------|----------------------------|
| Channel | Type | Value |
| ff | 03(SetReportingInterval) | b004=>04b0=1200s=20minutes |

2. Reboot the device.

| ff10ff | | |
|---------|------------|--------------|
| Channel | Type | Value |
| ff | 10(Reboot) | ff(Reserved) |

3. Set time zone to GMT-4.

| ff17d8ff | | |
|----------|--------------------|-------------------------------|
| Channel | Type | Value |
| ff | 17 (Set Time Zone) | d8 ff => ffd8 = -40 = -4 * 10 |

4. Set the device time.

| ff 11 3d 1c de 5d | | |
|-------------------|---------------------|--|
| Channel | Type | Value |
| ff | 11(Set Device Time) | 3d 1c de 5d=>5d de 1c 3d=1574837309(Unixtimestamp) =>2019/11/17 14:48:29 |

5. Set temperature threshold alarm.

| ff06 cc 9600 2c01 00000000 | | |
|----------------------------|--------------------|---|
| Channel | Type | Value |
| ff | 06(ThresholdAlarm) | Ctrl: cc=>11 001 100 100=beloworabove,001=temperature,1=enable Min_value: 96 00=>00 96=15°C |

| | | |
|--|--|------------------------------|
| | | Max_value: 2c 01=>01 2c=30°C |
|--|--|------------------------------|

6. Set rainfall threshold alarm: rainfall is over 995.35 mm.

| ff06 5a 0000 cf84 0000 0100 | | |
|-----------------------------|--------------------|--|
| Channel | Type | Value |
| ff | 06(ThresholdAlarm) | Ctrl: 5a=>01 011 010 010=above, 011=rainfall, 1=enable Max_value: cf 84 01 00=>00 01 84 cf=99535*0.01=995.35 mm |

5.4 Historical Data Enquiry

WS series support sending downlink commands to enquire historical data for specified time point or time range. Before that, ensure **the device time is correct and data storage feature was enabled to store the data.**

Command format:

| Channel | Type | Description |
|---------|---------------------------------|---|
| fd | 6b (Enquire data in time point) | 4 Bytes, unix timestamp |
| fd | 6c (Enquire data in time range) | Start time (4 bytes) + End time (4 bytes), Unix timestamp |
| fd | 6d (Stop query data report) | ff |
| ff | 6a (Report Interval) | 3 Bytes, Byte 1: 01 Byte 2: interval time, unit: s, range: 30~1200s (60s by default) |

Reply format:

| Channel | Type | Description |
|---------|--------------------|--|
| fc | 6b/6c | 00: data enquiry success 01:timepointortimerangeinvalid 02: no data in this time or time range |
| 21 | ce(HistoricalData) | Data time stamp (4 Bytes) + Temperature (2 Bytes) + Humidity(1Byte)+Pressure(2Bytes)+WindDirection (2 Bytes) + Wind Speed (2 Bytes) + Rainfall (4 Bytes) |

Note: 1. The device only uploads no more than 300 data records per range enquiry. 2. When enquiring the data in time point, it will upload the data which is closest to the search point within the reporting interval range. For example, if the device's reporting interval is 10

minutes and users send command to search for 17:00's data, if the device find there is data stored in 17:00, it will upload these data. If no, it will search for data between 16:50 to 17:10 and upload the data which is closest to 17:00. Example: 1. Enquire historical data between 2022/10/10 14:45:00 to 2022-10-10 15:35:00.

| fd6c c3291a63 b09a1a63 | | |
|------------------------|-----------------------------|---|
| Channel | Type | Value |
| fd | 6c(Enquiredataintime range) | Start time: 6cbf4363 => 6343bf6c = 1665384300=2022/10/1014:45:00 Endtime:24cb4363=>6343cb24= 1665387300 =2022-10-10 15:35:00 |

Reply:

| fc6c00 | | |
|---------|---------------------------------|--------------------------|
| Channel | Type | Value |
| fc | 6c (Enquire data in time range) | 00: data enquiry success |

| 21ce 60c34363 0e01 64 8c27 c706 0400 10000000 | | | |
|---|----------------------|--------------------------------|---|
| Channel | Type | TimeStamp | Value |
| 21 | ce (Historical Data) | 56991a63=> 2022-10-10 15:31:52 | Temperature: 0e 01=>01 0e=27°C Humidity: 64=>100=50% Barometric pressure: 8c 27=>27 8c=1012.4hPa WindDirection:c706=>06 c7=173.5° Wind Speed: 0400=>0004=0.4m/s Rainfall: 10 00 00 00=>00 00 00 10=0.16 mm |

-END-