

LINOVISION

Industrial Outdoor Wireless Bridge  
with PoE & RS485  
IOT-S306S  
Quick Guide (V1.1/2026-4-16)



Quick Guide

## Package Contents



IOT-W306S

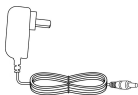

Power Adapter



Hoop



Quick Guide

## Interface

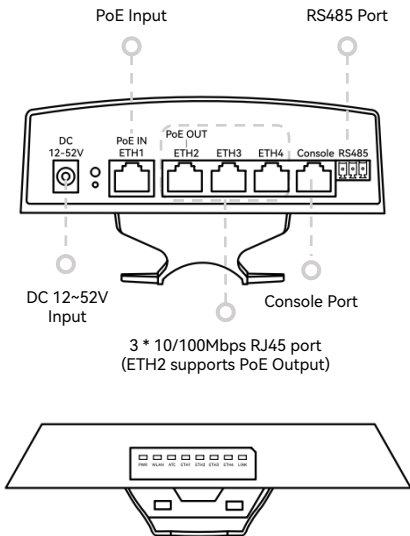

# Installation

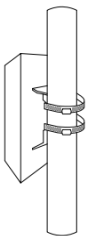

Wall Mounting & Pole-Mounting

# Connection Diagram

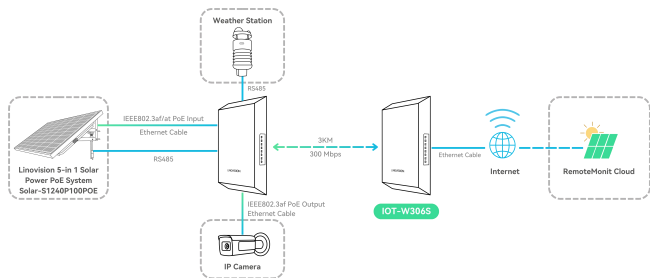

# WEB Login

## Web Login Steps

The device is factory-configured as AP (Transmitter) in an unpaired state. To establish a wireless bridge, configure the AP (Transmitter) first, then configure the CPE (Receiver).

### Step 1 Log In to the Web Management Page

**Note: This step applies to both the Transmitter (AP) and Receiver (CPE). Configure the IP address for each device to ensure they are accessible for subsequent setup.**

#### 1.1 Configure the PC IP Address

Set the PC IP address to the same subnet as the device default IP.

- IP address: 172.20.X.X
- Subnet mask: 255.255.0.0

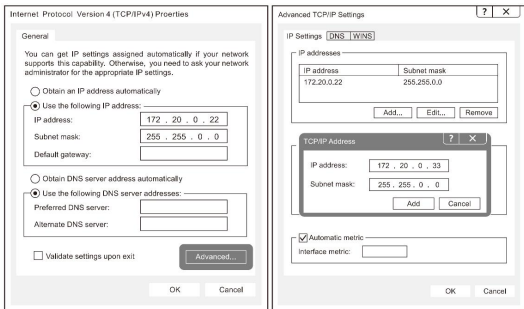

#### 1.2 Web Login

1. Open a web browser (Google Chrome or Microsoft Edge recommended).
2. Enter the device default IP address: <http://172.20.0.1>
3. Enter the login password and click Login.
  - Default IP address: 172.20.0.1
  - Password: admin

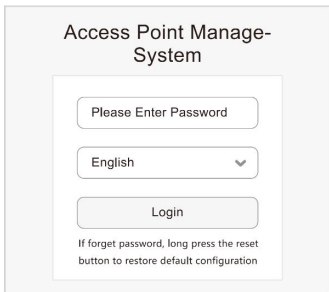

## Step 2 Wireless Configuration

### 2.1 AP (Transmitter) Setup

1. Go to Wireless.
2. Select AP (Transmitter) as the operating mode.

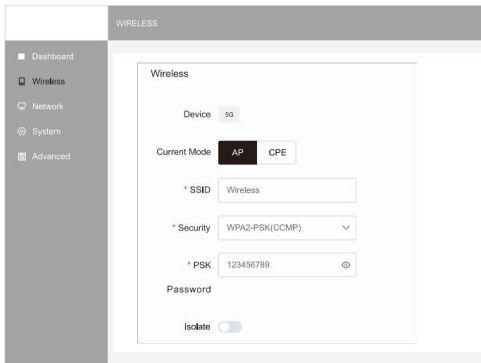

## Wireless Settings

- SSID: Wireless
- Security: WPA2-PSK (CCMP)
- Password (PSK): 123456789

***If multiple wireless bridge groups are required, modify the SSID to differentiate each group.***

### AP IP Address

- Default IP: 172.20.0.1
- The IP address can be modified if required.

3. Click Confirm to save the settings.

## 2.2 CPE (Receiver) Setup

1. Go to Wireless.
2. Select CPE (Receiver) as the operating mode.

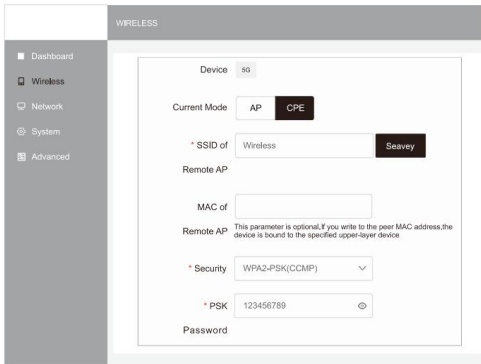

WIRELESS

■ Dashboard

📶 Wireless

🌐 Network

⚙️ System

🔧 Advanced

Device 99

Current Mode AP CPE

\* SSID of Wireless Seavey

Remote AP

MAC of

Remote AP This parameter is optional. If you write to the peer MAC address, the device is bound to the specified upper-layer device.

\* Security WPA2-PSK(CCMP) ▾

\* PSK 123456789 ⓘ

Password

## Wireless Pairing

- Scan and select the SSID from the AP, then enter the wireless password or Manually enter the SSID and password
- Default SSID: Wireless
- Default Password: 123456789

***Pairing is successful when the SSID and password match those of the AP.***

## CPE IP Address

- Default IP: 172.20.0.2
- The IP address can be modified if required.

For point-to-multipoint applications, each device must use a unique management IP address.

### ***Example:***

- AP: 172.20.0.1
- CPE 1: 172.20.0.2
- CPE 2: 172.20.0.3

3. Click Confirm to save the settings.

## Step 3 Network Configuration

Note: Select either Dynamic IP or Static IP.

### 3.1 Dynamic IP (DHCP)

Select Dynamic IP to automatically obtain network parameters.

- WAN Type: Dynamic IP

Click Confirm to save.

The screenshot shows a web interface for network configuration. On the left is a sidebar menu with options: Dashboard, Wireless, Network (selected), System, and Advanced. The main content area is titled 'NETWORK' and contains a 'Network Address' section. This section has two input fields: '\*WAN Type' with a dropdown menu set to 'Dynamic IP', and 'DNS Server' with the value '223.5.5.5'. Below these fields is a black 'Confirm' button.

## 3.2 Static IP

Select Static IP to manually configure network parameters.

- IP Address
- Netmask
- Gateway
- DNS Server

Click Confirm to save.

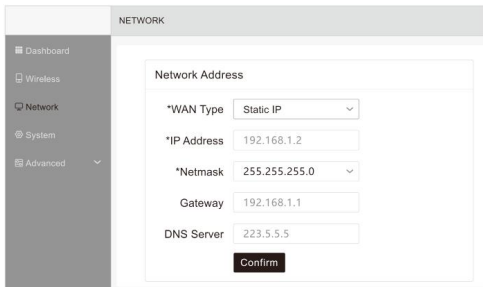

The screenshot shows the 'NETWORK' configuration page in the RemoteMonit interface. On the left is a sidebar with navigation options: Dashboard, Wireless, Network (selected), System, and Advanced. The main content area is titled 'Network Address' and contains the following fields:

- \*WAN Type: Static IP (dropdown menu)
- \*IP Address: 192.168.1.2 (text input)
- \*Netmask: 255.255.255.0 (dropdown menu)
- Gateway: 192.168.1.1 (text input)
- DNS Server: 223.5.5.5 (text input)

A 'Confirm' button is located at the bottom of the configuration area.

## TCP Gateway Configuration

### 1. Add a New TCP Gateway

Step 1. Log In to the RemoteMonit Platform

- Open the RemoteMonit platform at <https://remotemonit.com/> and log in to your account.
- If you do not have an account, please register a new one first.

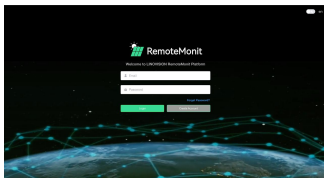

## Step 2. Add a New TCP Gateway

In the left sidebar, navigate to:  
Gateways → TCP Gateways → + New  
to add a new TCP gateway.

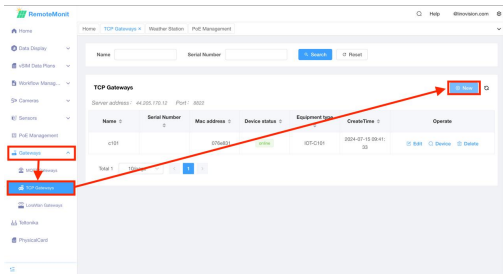

## Step 3. Configure Gateway Information

Fill in the required information as follows:

- Name: The gateway name. This field can be customized.
- Equipment Type: Select the appropriate device model based on your current device.
- MAC Address: The MAC address can be found on the label on the back of the device or on the device configuration details page.
- Serial Number: (Optional) Used to identify or manage specific device information.
- Time Interval: The data transmission interval of the TCP gateway. Select a value between 10–300 seconds according to your application requirements.

New

\* Name

\* Equipment type

\* Mac address

Serial Number

\* TimeInterval  s

Cancel Confirm

## 2. Match the Gateway

The RemoteMonit platform supports IOT-W306S as a TCP Gateway. Follow the steps below to connect the device to the RemoteMonit platform.

### Step 1. Download the Configuration Tool

Scan the QR code on the front page to download VirCom\_en.rar.

### Step 2. Select the Device

Extract VirCom\_en.rar, then open the tool. Select Device, and choose the device you want to connect to the RemoteMonit platform.

### Step 3. Configure TCP Client Parameters

Configure the parameters as follows:

- Set Register Pkt to match the Dev ID
- Select TCP Client as the Work Mode
- Set Dest. IP/Domain and Dest. Port to match the Server Address and Port shown on the RemoteMonit platform

The image shows two screenshots. The left screenshot is the 'Device Settings' window of the VirCom tool. The 'Device Info' tab is active, showing 'Dev ID' as '287100000000' and 'Dev Name' as 'JLDCV0861'. The 'Network' tab shows 'Work Mode' set to 'TCP Client', 'Dest. IP/Domain' as '141.230.118.81', and 'Dest. Port' as '8080'. The 'Advanced Settings' tab shows 'Register Pkt' set to '287100000000'. The right screenshot is the RemoteMonit platform interface, showing a table of TCP Gateways. The first row is highlighted, showing 'Name: JLDCV0861', 'Serial Number: 287100000000', 'Device status: Online', and 'Server IP: 141.230.118.81'. The 'Server IP' field is highlighted in red.

### Step 4. Apply Settings

Click Modify Setting.

When the device status shows Online on the RemoteMonit platform, the configuration is complete.

# Specifications

Hardware Specifications		
DRAM	DDR2, 64 MB	
Flash	8 MB	
Network & Device Interfaces		
Ethernet Ports	3 × 10/100 Mbps RJ45 ports (1 port supports IEEE 802.3af PoE output; 1 port supports IEEE 802.3af/at PoE input)	
Uplink Port	1 × 10/100 Mbps uplink Ethernet port	
Console Port	1 × console port	
RS485 Interface	1 × RS485 interface	
DC Power Interface	1 × DC input (DC 12–52 V, 2 A input; internally boosted to DC 48 V to enable IEEE 802.3af PoE output on ETH2; maximum output power 15 W)	
Wireless Data Rates		
802.11a	54, 48, 36, 24, 18, 12, 9, 6 Mbps	
802.11n HT20	7.2, 14.4, 21.7, 28.9, 43.3, 57.8, 65, 72.2, 86.7, 115.6, 130, 144.4 Mbps	
802.11n HT40	15, 30, 45, 60, 90, 120, 135, 150, 180, 240, 270, 300 Mbps	
Wireless Technology		
Transmission Method	Direct Sequence Spread Spectrum (DSSS)	
Modulation	OFDM / BPSK / QPSK / CCK / DQPSK / DBPSK	
Standards & Protocol Support		
Wireless Standards	IEEE 802.11n, IEEE 802.11a	
Ethernet Standards	IEEE 802.3, IEEE 802.3u, IEEE 802.3x	
PoE Standards	IEEE 802.3af, IEEE 802.3at	
Network Protocols	CSMA/CA, TCP/IP, IPX/SPX, NetBEUI, DHCP, NDIS3, NDIS4, NDIS5	
RF Characteristics		
Frequency Range	4900–6100 MHz	
RF Output Power (@25 °C ±2 dB)		
802.11a	6–24 Mbps	27 ±2 dBm
	36–48 Mbps	26 ±2 dBm
	54 Mbps	25 ±2 dBm

# Specifications

802.11a	6–24 Mbps	27 ±2 dBm
	36–48 Mbps	26 ±2 dBm
	54 Mbps	25 ±2 dBm
802.11n HT20	MCS 0–3	27 ±2 dBm
	MCS 4	26 ±2 dBm
	MCS 5	25.5 ±2 dBm
	MCS 6	25 ±2 dBm
	MCS 7	24.5 ±2 dBm
802.11n HT40	MCS 0–3	26 ±2 dBm
	MCS 4	25.5 ±2 dBm
	MCS 5	25 ±2 dBm
	MCS 6	24.5 ±2 dBm
	MCS 7	24 ±2 dBm
<b>Receiver Sensitivity</b>		
802.11a	6Mbps ≤ -89; 54Mbps ≤ -73	
802.11n	HT20	MCS 0 ≤ -86; MCS 7 ≤ -68
	HT40	MCS 0 ≤ -83; MCS 7 ≤ -65
<b>Antenna</b>		
Frequency Range	4900–6100 MHz	
Polarization	Vertical / Horizontal	
Gain	16 dBi	
<b>Switching &amp; Forwarding Performance</b>		
Switching Capacity	1 Gbps	
Packet Forwarding Rate	12.96 Mpps	
Forwarding Mode	Wire-speed forwarding on all ports	
MAC Address Table	4K	
Port Auto-Negotiation	Supported	
<b>Power System</b>		
Power Input	DC 12–48 V / PoE 48 V	
Boost Converter Input	DC 12–36 V, 2 A	

# Specifications

Maximum PoE Output Power	15 W
Power Consumption	≤ 6 W
<b>Management &amp; Security</b>	
Management Methods	WEF-based management, SNMP MIB, Telnet, Serial
MAC Address Control	Not supported
Encryption	WEF (64/128-bit), WPA, WPA2, 802.1X
<b>Serial Device Server (RS485)</b>	
Interface	RS485 terminal
Ethernet Protection	RJ45 interface, 2 kV surge protection
Serial Signals	RXD, TXD, GND
Baud Rate	300–115200 bps
Parity	None, Odd, Even, Mark, Space
Data Bits	5–9 bits
Flow Control	None
<b>Software &amp; Configuration</b>	
Supported Protocols	Ethernet, IP, TCP, UDP, HTTP, ARP, ICMP, DHCP, DNS
Configuration Methods	ZLVirCOM tool, Web browser, device management function library
Communication Method	TCP/IP direct communication, virtual serial port mode
<b>Operating Mode</b>	
Operating Temperature	-30 to +65 °C
Storage Temperature	-50 to +80 °C
Humidity (Non-condensing)	≤95% (non-condensing)
Humidity (Non-condensing)	≤95% (non-condensing)
<b>Product Specifications</b>	
Dimensions (L × W × H)	228 × 135 × 45 mm (8.98 × 5.31 × 1.77 in)
Weight	0.4 kg (0.88 lb)

## LED Indicators

LED	Status	Indication
PWR	On	Power is on and device is operating normally
WLAN	On	Wireless signal is transmitting normally
ATC (Uplink Port)	On	Uplink port is connected normally
	Blinking	Data is being transmitted
ETH 1-4	On	Ethernet port is connected normally
	Blinking	Data is being transmitted
Link (RS-485 Port)	On	RS-485 connection is established normally
	Blinking	Data is being transmitted